



## USB I/O Data Sheet

### **802x00**

**802600 USB Chip 16 Bit IO SOIC24**

**802300 USB Chip 12 Bit IO DIP20**

**802200 USB Chip 12 Bit IO SOIC20**

### **802x70**

**802270 USB Chip 10 Bit IO SOIC18**

**802370 USB Chip 10 Bit IO DIP18**

**802670 USB Chip 16 Bit IO SOIC24**

**802770 USB Chip 16 Bit IO DIP24**

Delcom Products  
200 William Street  
Port Chester, NY 10573  
914-934-5170  
914-934-5171 Fax  
[www.delcom-products.com](http://www.delcom-products.com)

# Contents

- 1.0 Functional Overview**
- 2.0 Pin Definitions**
- 3.0 Pin Descriptions**
- 4.0 Features**
  - 4.1 Write Strobe**
  - 4.2 Clock Generator**
  - 4.3 Port Setup**
  - 4.4 Read Buffer**
  - 4.5 Scratch Pad**
  - 4.6 Event Counter**
  - 4.7 Status LED**
  - 4.8 RS232 Serial Port**
  - 4.9 I<sup>2</sup>C Port**
  - 4.10 64 Bit Read/Write IO Command**
  - 4.11 SPI Port**
  
- 5.0 Firmware Commands**
  - 5.1 General**
  - 5.2 Command Packet Format**
  - 5.3 Write Commands**
  - 5.4 Read Commands**
  
- 6.0 Typical Schematic**
  
- 7.0 Specifications**
  - 7.1 Absolute Maximum Ratings**
  - 7.2 Electrical Characteristics**
  
- 8.0 Package Diagrams**
- 9.0 Ordering Information**
- 10.0 Firmware Release Notes**
- 11.0 TroubleShooting**
- 12.0 Notes**
  - 12.1 Power Notes**
  - 12.2 Interfacing Notes**

## 1.0 Functional Overview

The Delcom USB IO chips provide a preprogrammed low cost solution to USB peripherals. These chips are based on the Cypress™ CY7C63xxx and the CY7C637xx USB chips. The USB IO chip are preprogrammed with to support USB connectivity. The chips conform to the USB 1.1 standard.

The data sheets describes both the 802x00 and 802x70 USB chips. For new designs it is recommended to use the newer 802x70 USB chips.

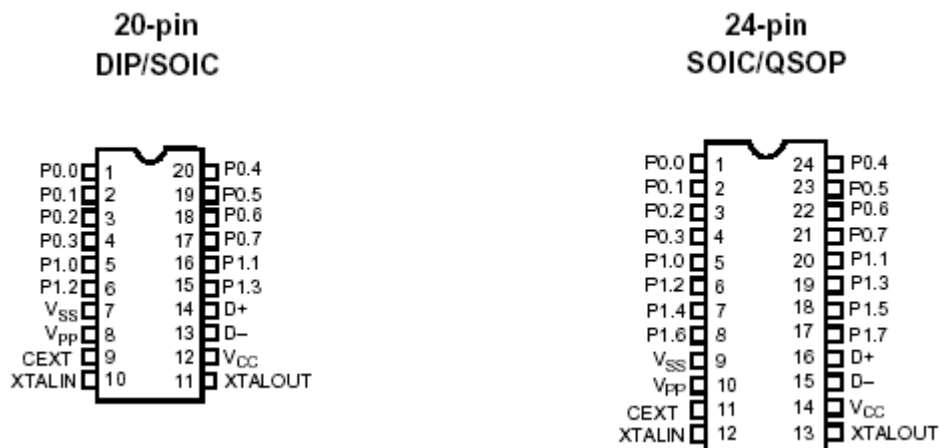

For more information on this device see Cypress™ data sheet CY7C63000A, available on our website.

## 2.0 Pin Definitions

Name	I/O	802200 802300 20-Pin	802600 24-Pin	Description
P0.0	I/O	1	1	Port 0 bit 0 (I2C SCLK)
P0.1	I/O	2	2	Port 0 bit 1 (I2C SDA)
P0.2	I/O	3	3	Port 0 bit 2
P0.3	I/O	4	4	Port 0 bit 3
P0.4	I/O	20	24	Port 0 bit 4
P0.5	I/O	19	23	Port 0 bit 5 (SPI MISO)
P0.6	I/O	18	22	Port 0 bit 6 (SPI MOSI)
P0.7	I/O	17	21	Port 0 bit 7 (SPI SCLK)
P1.0	I/O	5	5	Port 1 bit 0
P1.1	I/O	16	20	Port 1 bit 1
P1.2	I/O	6	6	Port 1 bit 2
P1.3	I/O	15	19	Port 1 bit 3
P1.4	I/O	-	7	Port 1 bit 4
P1.5	I/O	-	18	Port 1 bit 5
P1.6	I/O	-	8	Port 1 bit 6
P1.7	I/O	-	17	Port 1 bit 7
XTALIN	I	10	12	Clock In*
XTALOUT	O	11	13	Clock Out*
CEXT	I/O	9	11	Wake Up Pin
D+	I/O	14	16	USB Data +
D-	I/O	13	15	USB Data -
Vpp	-	8	10	Programming voltage, Connect to Vss
Vcc	-	12	14	Voltage Supply
Vss	-	7	9	Ground

## 3.0 Pin Descriptions

Name	Description
Vcc	Voltage Supply. Nominal 5V, Range 4.0Volts to 5.25Volts
Vss	Ground. Connect to ground
XtalIn	Clock Input
XtalOut	Clock Output
P0.0-7	Port 0. Low Current GPIO. Programmable sink current & pullup.
P1.0-7	Port 1. High Current GPIO. Programmable sink current & pullup.
D+,D-	USB data lines. Requires an external 7.5K resistor connected to D- to Vcc.
Vpp, Cext	Unused pins. Vpp connect to ground. Cext leave open.

**\*Note** - The 802x00 chips require a external 6MHz ceramic resonator as it's clock source. The 802x70 chips do not require an external oscillator.

## 4.0 Programmed Features

The USB I/O chip provides general 8 bit input output commands as well as individual set and reset commands of each pin.

### 4.1 Write Strobe

The write strobe feature allows the USB I/O chip to interface to another device by using a standard 8-bit data bus with a strobe pin. The data is placed on port 0 and the strobe is selectable on one of the port 1 pins. These functions allow one to eight data bytes to be sent on either a positive and negative strobe (pulse). The write strobe functions support an optional acknowledge signal.

### 4.2 Clock Generator

This function generates a clock source with variable frequency and duty cycle. Up to four separate clocks can be configured. The clock outputs can be selected on port 1 pins 0 through 3.

### 4.3 Port Setup

These features allow the user to set the programmable output sink current and enable/disable the port pin pull up resistor. Each port pin is of an open collector type. The sink current level can be set in 16 levels. Each port pin has a pull up resistor of 16Kohms that can be enabled or disabled.

### 4.4 Read Buffer

This feature allows the USB I/O chip to interface to a device using a standard 8-bit data bus and a read strobe pin. Data is read on port 0 with a read strobe (pulse) on one of the selectable port 1 pins. The data read buffer is 7 bytes deep. If the read data buffer is full, new data will not be accepted and the over flow flag will be set. Note this function cannot be used while the RS232 functions are in uses.

### 4.5 Scratch Pad

The scratch pad allows the user to write 8 bytes of user defined information in to the USB I/O device. This area can be used for storing user variables, states or other information. Note this function cannot be used while the RS232 functions are in uses.

### 4.6 Event Counter

The event counter feature allows the counting of events on one of the port 0 pins. The resolution of the counter is 4 bytes. The active level on the count pins is user selectable.

### 4.7 Status Led

The status led feature toggles a port pin when there is activity on the USB bus. The feature is only available on pin P1.3. The pin goes low while the USB I/O chip is processing the USB command. The active low pulse is short and therefore may requires a pulse stretcher circuit in order to view.

### 4.8 RS232 Serial Port

The RS232 functions allow the chip to interface to a RS232 compliant device. Currently the baud rate is fixed at 2400bit/sec with 8 data bit, one stop bit and no parity. To use the RS232 function first enable it with commands 10-40, then use command 10-50 to send data and 11-50 to receive data. You can check the internal buffer count with command 11-9. The RS232 pins are fixed with transmit at port 0 pin 7, receive at port 0 pin 6 and clear to send at port 0 pin 5. This commands supports a maximum transfer of 7 bytes per command.

### 4.9 I<sup>2</sup>C Port

The I2C functions allow the chip to interface to an I2C compliant device. The I2C port supports the standard clock rate of 100KHz. The SCLK signal is on port 0 pin 0 and the SDA signal is on port o pin 1.

There are four commands associated with the I2C port. They are 10-60 Write, 10-61 Selective read setup, 11-60 Read and 11-61 Selective read. This command supports a maximum transfer of eight bytes per command.

#### **4.10 64 Bit Read/Write command**

The 64 bit read/write commands allows the user to read or write 64 bits (8 Bytes) of data with one command. This commands requires extra hardware. See the USB64BIO-Sch.pdf schematic on our website.

#### **4.11 SPI Port**

Available in 802x70 chips only.

The SPI functions allow the chip to interface to an SPI compliant device. The I2C port supports a variable clock period from 20ns to 5.1ms. The default clock is 200ns and can be changed with command 10-91.

There are three SPI commands they are 10-90 Write SPI Data, 11-90 Read SPI Data and 11-91 Write 8 bits Read 1-64 bits. The SCLK signal is on port 0 pin 7, the MOSI signal is on port 0 pin 6 and the MISO signal is on port 0 pin 5. This command supports a maximum transfer of eight bytes per command.

## 5.0 Firmware Commands

### 5.1 General

All commands are passed to the USB I/O device in a command packet. The command is filled and sent to the USB I/O device using the DeviceIOControl Windows™ function in the Setupapi.dll. Alternatively you can use the DelcomDLL which has specific functions already defined. See the USB I/O Programming Manual and the Delcom DLL Manual available on our web site for more information.

All command packets are at least 8 byte long (16 bytes Max) and all receive data is 8 bytes long.

### 5.2 Command Packet Format:

Recipient	Byte	Always 8 for the USB IO device.
Device Model	Byte	Always 18 for the USB IO device
Major Command	Byte	See Below
Minor Command	Byte	See Below
Data LSB	Byte	See Below
Data MSB	Byte	See Below
Length	Short (2 Bytes)	Length of DataExtension.
DataExtension	0-8 Bytes	– (Optional) Version 5 and up.

## 5.3 Write Commands

Command Number		Data Length	Command Description	VER Family
Major	Minor			
10	-	-	<b>WRITE FUNCTIONS</b>	
-	-	-	<b>Port Write Functions</b>	
10	0	0	<i>Dummy command.</i> Does nothing, used for testing.	
10	1	0	<i>Writes the LSB to port 0.</i> Port 0 is defaulted high after reset.	
10	2	0	<i>Writes the LSB to port 1.</i> Port 1 is defaulted high after reset.	
10	10	0	<i>Writes the LSB to port 0 and the MSB to port 1.</i>	
10	11	0	<i>Sets or resets the port 0 pins individually.</i> The LSB resets the corresponding port pin(s) and the MSB sets the corresponding port pin(s) on port 0. Resetting the port pin(s) takes precedence over setting the bits.	
10	12	0	<i>Sets or resets the port 1 pins individually.</i> The LSB resets the corresponding port pin(s) and the MSB sets the corresponding port pin(s) on port 1. Resetting the port pin(s) takes precedence over setting the bits.	
10	13	0	<i>Write strobe high function.</i> This commands writes the LSB to port 0 and then toggles the corresponding pin marked in the MSB byte high then low. See Write strobe function sequence below.	
10	14	0	<i>Write strobe low function.</i> This commands writes the LSB to port 0 and then toggles the corresponding pin marked in the MSB byte low then high. See Write strobe function sequence below. <i>Write strobe function sequence.</i> This command produces the following sequence; 1) Data in LSB is written to Port 0. 2) The strobe pin is set active for 1.5ms. If the acknowledge pin is enabled the strobe pin will wait while the acknowledge pin is held low (See command 10-40 bit 3). 3) Then the strobe pin is made non-active. 4) And finally 0xFF is written to Port 0. The strobe pin and the data on port 0 must be initially preset before using this function.	
10	15	1-8	<i>Write 8-byte strobe high function.</i> This commands writes the Data Extension data to port 0 and then toggles the corresponding pin marked in the MSB byte high then low and then delays for the specified time set in the LSB byte. See Write 8-byte strobe function sequence below.	5
10	16	1-8	<i>Write 8-byte strobe low function.</i> This commands writes the Data Extension data to port 0 and then toggles the corresponding pin marked in the MSB byte low then high and then delays for the specified time set in the LSB byte. See Write 8-byte strobe function sequence below. <i>Write 8-byte strobe function sequence.</i> This command produces the following sequence; 1) Data in Data Extension is written to Port 0 LSB first. 2) The strobe pin is set active for 1.5us. If the acknowledge pin is enabled the strobe pin will wait while the acknowledge pin is held low (See command 10-40 bit 3). 3) Then the strobe pin is made non-active. 4) And finally 0xFF is written to Port 0. 4) System then delays for the specified time set in Data LSB byte. 5) Then the process is repeated till all data bytes in the Data Extension have been sent. The delay is equal to 8.25us+(0.75us*DelayValue) Example: Command 8,18,10,15,10,1,4,0,0,0,0 will send 4 bytes of data (all zeros here) on a high strobe on pin one with a delay of 15.75us. The strobe pin and the data on port 0 must be initially preset before using this function.	5
10	17	8	<i>Write 64 Bit Command.</i> This command writes 8 bytes of data to the external hardware latches. The data is passed in the data extension registers. The LSB of the data extension is written to address zero. This commands requires external hardware. See USB64BIO-Sch.pdf on our website.	8
10	19	0	<i>Loads the Clock Generator Global Pre-scalar value.</i> Default value is 10, range = 1 to 255. This value is passed in the LSB register. Increasing this number decreases all the clock function frequencies.	
10	20	0	<i>Enables or disables the clock generator on port 1.</i> The lower nibble of the LSB disables the corresponding port pin(s) and the lower nibble of the MSB enables the corresponding port pin(s). Disabling the port pin(s) takes precedence over enabling.	
10	21	0	<i>Loads the frequency and duty cycle for port 1 pin 0.</i> See below for format.	
10	22	0	<i>Loads the frequency and duty cycle for port 1 pin 1.</i> See below for format.	
10	23	0	<i>Loads the frequency and duty cycle for port 1 pin 2.</i> See below for format.	
10	24	0	<i>Loads the frequency and duty cycle for port 1 pin 3.</i> See below for format. <i>Frequency and duty format.</i> The LSB sets the period when the port pin is high and the MSB sets the period when the port pin is low. The resolution of the period is 10ms. The resolution of the duty cycle is 0.39 percent. The minimum clock frequency is 25.6 seconds at 50% duty. The maximum clock frequency is 100ms at 50% duty. Clock pins can be preset to a predefined state	
10	25	0	<i>Synchronizes the clock generation.</i> This command synchronizes all the clock generators to start at an initial phase delay, see below. The lower nibble of the LSB enables this function on the corresponding pins P1.0 to P1.3. The lower nibble of the MSB presets the initial value on the corresponding pins P1.0 to P1.3. Initial phase delay resolution is in 10ms and is passed in the LSB register. Initial phase delay registers are cleared after this command is sent. Therefore the initial phase delay registers must be set each time this command is called.	
10	26	0	<i>Load initial phase delay on port 1 pin 0.</i> See Synchronies function above.	
10	27	0	<i>Load initial phase delay on port 1 pin 1.</i> See Synchronies function above.	
10	28	0	<i>Load initial phase delay on port 1 pin 2.</i> See Synchronies function above.	
10	29	0	<i>Load initial phase delay on port 1 pin 3.</i> See Synchronies function above.	
-	-	-	<b>Port Setup Functions</b>	
10	30	0	<i>Enable or disable port 0 pull up resistors.</i> A low bit in the LSB enable the corresponding port 0 pull up. A high bit in LSB disables the corresponding port 0 pull up. The pull up resistor value is 16K. Default value is 0x00, all port 0 pull ups enabled.	
10	31	0	<i>Enable or disable port 1 pull up resistors.</i> A low bit in the LSB enables the corresponding port 1 pull up. A high bit in LSB disables the corresponding port 1 pull up. The pull up resistor value is 16K. Default value is 0x00, all port 1 pull ups enabled.	
10	32	0	<i>Setup port 0 pins sink current level.</i> This functions sets the current sinking level of the port 0. The maximum	



current sinking ability of port 0 is 1.5mA and the minimum current sinking ability is 0.3mA. The default value for port 0 is 0x00. See below for format.

10 33 0 *Setup port 1 pins sink current level.* This functions sets the current sinking level of the port 0. The maximum current sinking ability of port 1 is 24mA and the minimum current sinking ability is 1.5mA. The default value for port 1 is 0x00. See below for format.

*Setup port pin sink current level.* The MSB selects which pin to set the sinking current level on. A zero in the MSB selects the pin 0 and a 7 in the MSB selects pin 7. The lower nibble of LSB sets the current sinking level of the port pin. A LSB of 0x00 sets the lowest current level and a LSB of 0x0F sets the highest current level. Default value is 0x00, lowest current setting. Both ports can only source current at Vcc/16K when the pull up is enabled, for example if the Vcc is 5volts a port pin would source 0.3mA maximum.

10 34 0 *Load the PWM value for ports P1.0, P1.1, P1.2 and P1.3.*  
Port pins P1.0 through P1.3 can be placed in PWM mode by writing the PWM value with this command. The LSB Data parameter is the port pin number, range is 0-3. The MSB Data parameter is the PWM value, range is 0-100. 802x70

**Feature commands**

10 35 0 *Setup read buffer function.* This command sets up the micro to read the current values on port 0 when a read strobe is presented on the configured strobe pin on port 1. The LSB will enable the correspond pin on port 1 to latch data on port 0 on the active edge. The active edge is set up the pull ups command 10-30 and 10-31. If the pull-ups are enabled then the active transition is from high to low. Otherwise the active transition is from low to high. The read buffer is only 7 bytes deep. Default is 0x00, read buffer disabled. See read buffer command below (11-5). Note this function cannot be used while the RS232 functions are in uses.

10 37 0 *Write scratch pad area.* Writes the LSB to the scratch pad. The MSB contains the pointer to the scratch pad. Pointer values can range from 0 to 7. The scratch pad area is 8 bytes deep. This area can be used for storing user variables, states or information. Defaulted to all 0x00 on boot up. Note this function cannot be used while the RS232 functions are in uses.

10 38 0 *Enable/Disable Events Counter.* This command sets up the event counter. LSB data byte enables this function on the corresponding pin on port 0. The MSB data byte disabled this function on the corresponding pin on port 0. Once enabled the system will count events on the enabled pin on the active edge. The active edge is configured by the pull ups command 10-30 and 10-31. If the pull-ups are enabled then the active transition is from high to low. Otherwise the active transition is from low to high. The event counter value is read with command 11-8. This feature is off by default.

10 40 0 *Enable/Disable Control Register.* This function sets the control register value. Each bit in this register controls different options. The LSB data byte is written to this control register.  
Bit 0: Status LED. When set Port1 pin 3 (P1.3) will toggle low when USB communications are present. Only available on this pin.

Bit 1: Enables the RS232 Serial port with fixed 2400 baud rate. Version 5.

Bit 3: Enables the acknowledge pin in the write strobe functions 13,14,15 & 16. The acknowledge pin is only available on pin P1.2 and is active low. The write strobe will be extended while the acknowledge pin is held low. Version 8.

Bits7-4,2: Future Implementation. These bits are reserved for future implementation and should be set to zero for future compatibility.

10 43 0 Set Port 0 Interrupt Edge.

The LSB Data parameter sets the Port 0 Interrupt Edge. 1= Rising edge, 0=Falling edge. 802x70

10 44 0 Set Port 1 Interrupt Edge.

The LSB Data parameter sets the Port 1 Interrupt Edge. 1= Rising edge, 0=Falling edge. 802x70

10 45 0 Configures Port 0 GPIO – Mode 0 Register

The LSB data parameter is the value passed. Each bit represents a port pin. See the GPIO Mode table below. 802x70

10 46 0 Configures Port 0 GPIO – Mode 1 Register

The LSB data parameter is the value passed. Each bit represents a port pin. See the GPIO Mode table below. 802x70

10 47 0 Configures Port 1 GPIO – Mode 0 Register

The LSB data parameter is the value passed. Each bit represents a port pin. See the GPIO Mode table below. 802x70

10 48 0 Configures Port 1 GPIO – Mode 1 Register

The LSB data parameter is the value passed. Each bit represents a port pin. See the GPIO Mode table below. 802x70

GPIO Mode table

Mode 1 Value	Mode 0 Value	Port type when data out is low	Port type when data out is high	
0	0	Hi-Z / CMOS	Hi-Z / TTL	
0	1	Medium (8mA) Sink / CMOS	High (30mA) Drive / CMOS	
1	0	Low (2mA) Sink / CMOS	Pull up (14K) / CMOS	Default / Boot up Mode
1	1	High (50mA) Sink / CMOS	High (30mA) Drive / CMOS	

Maximum cumulative source drive current for all GPIO is 30mA.

Maximum cumulative sink drive current for all GPIO is 70mA.

See <http://www.delcom-eng.com/downloads/cy7c637xx-B.pdf> for more GPIO details.

10 50 1-8 *Writes to the RS232 Serial Port* 5

This command sends data to the serial port. Both the data count and data are passed in the Data Extension. The MSB and LSB bytes should be zero. The data count is in the LSB byte ( first byte of the DataExt) and the data is in the remaining 7 bytes. Issuing this command clears the TX Status register (see 11-9). Example command 8,18,0,0,6,5,1,2,3,4,5 will send 5 bytes of data (1,2,3,4,5) to the serial port.

10 60 1-8 *Write to the I2C Port* 6

			This command write the data found in the data extension to the I2C device. The device address/command is set in the Data LSB byte and the number of bytes to send is set in the Data MSB byte. If an error occurs bit 4/7 of byte 7 is set, else reset. See command 11-9.	
10	61	0	<i>I2C Selective Read Setup</i> This commands setups the selective read command 11-61. The Data LSB should be set to the device address/command and the Data MSB should be set to the selective read address. See 11-61 for more information.	6
10	77	8	<i>Toggle Pin Function</i> This command will toggle the GPIO pins. Any GPIO pin on ports port0 and port1 can be toggled. To toggle GPIO on port0 set the corresponding pin high in the LSBData parameter. For port1 use the MSBData parameter. The function will toggle all the pins marked in LSBData and MSBData for X number of times. The number of times -1 is passed in the DataExt0 variable. The DataExt1 variable holds the delay parameter. The delay value equals $6\mu s + (0.76\mu s * \text{DelayValue})$ . See Toggle Pin Command for more in for. This	21 802x70
10	86	8	<i>Pulse Pin Function</i> This command allows the user to send a custom pulse stream on port 0 or port 1. The command number is 76. All 8bits on either port0 or port1 can be changed. The LSBData parameter contains the delay prescaler and the port select bit. Bit 7 of the LSBData selects the port, a low selects port 0 and high selects port 1. The remaining bits 6 through 0 hold the prescaler value. The prescaler range is 0 to 127. The delay between the states is equal to $(\text{DelayValue} + 1) \times \text{Prescalar} \times \sim 2\mu s$ . There are 5 port pin state change parameters and 4 delay parameters. The change the port data parameters change the port value by executing a XOR with the current port value and the StateXPortXORData value. So to toggle a pin set the StateXPortXORData bit value high. You can toggle as many pins as you like. Up to 5 states can be set, for less than 5 states set the remaining data to all zeros. The initial port value should be preset with the write port command. Note this command processes inline and therefore no other command will be processed till this command terminates.	20 802x70
10	90	0-8	<i>Write to the SPI port</i> This commands writes up to 8 bytes of data (passed in the DataExt) to the SPI port. The number of bit to write is passed in the LSB Byte, range is 1-64. Also see command 11-91	15 802x70
10	91	0	<i>Setup SPI Port</i> This command configures the SPI CLK timing. The LSB byte specify the SPI clock period. Default is 10 and the units are 20us.	15 802x70

## 5.4 Read Commands

ver

Command Number		Data Length	Command Description	
Major	Minor			
11	-	-	<b>READ FUNCTIONS</b>	
			All read functions return 8 bytes. See individual commands for format.	
11	0	0	<i>Read ports 0 and port 1.</i> The first byte (LSB) will contain the current value on port 0 and the second byte (MSB) will contain the current value on port 1.	
11	1	0	<i>Reads port 0 with High strobe.</i> Reads the current data on port 0 with a high strobe on pin X on port 1. The LSB sets up which pin is to be used for the high strobe. See Read port 0 with strobe sequence below.	
11	2	0	<i>Reads port 0 with Low strobe.</i> Reads the current data on port 0 with a low strobe on pin X on port 1. The LSB sets up which pin is to be used for the low strobe. See Read port 0 with strobe sequence below. <i>Read port 0 with strobe sequence.</i> These commands produce the following sequence; 1) The selected strobe pin is made active. 2)Micro waits 1.5ms. 3) Data is latch from port 0 and stored. 4) The strobe pin is released. The strobe pin and the data on port 0 must to preset before using this function. Default is 0x00, command disabled.	
11	5	0	<i>Reads the Read Buffer.</i> This command is setup with the read Buffer Setup Command(10-35). The LSB byte returned is the read buffer status byte, it will contain the number of bytes available in the read buffer. The next 7 bytes contain the data. The read data buffer is only 7 bytes deep. Data is filled from byte 1 to byte 7. If the read data buffer is full and another read strobe is presented then the read buffer status byte will be set to 0xFF and the new data byte would be lost. The user must check the read status byte to if; new data is present, not present or present with data over run. This commands resets the read status byte to zero. Note this function cannot be used when the RS232 function is in use.	
11	7	0	<i>Reads the 8 bytes in the scratch pad area.</i> Default values are zero.	
11	8	0	<i>Reads the event counter value.</i> This command returns the 4 byte event counter value and then resets the counter. If the counter over flows then the over flow status byte will be set to 0xFF otherwise it will be 0x0. The event counter is returned in the first 4 bytes and the over flow byte is in the 5 byte.	
11	9	0	<i>Reads system variables.</i> This function returns the following system variables. Byte0: Control Register. Byte1: Clock Generator Pre-Scalar. Byte2: Port 0 Pull Up Register. Byte3: Port 1 Pull Up Register. Byte4: USB Port Address. Byte5: RS232 Rx Status. Returns the available data count in the lower nibble. Bit 7of 7 is set on Rx Buffer overflow and bit 6/7 is set on Rx framing error. Byte6: RS232 Tx Status. The lower nibble returns the number of data bytes still pending in the Tx buffer. Bit 7of 7 is set on a Tx buffer overflow. Byte7: Bit 4/7 is set if an I2C error is detected. This bit is update each time an I2C function is called.	
11	10	0	<i>Reads the firmware information.</i> Byte 0-3: Unique Device Serial Number. DWORD Little Endian. Byte 4: Firmware Version. Byte 5: Firmware Date. Byte 6: Firmware Month. Byte 7: Firmware Year.	
11	12	0	<i>Reads 8 bytes of memory data.</i> This is peek functions used only for firmware debugging. The LSB data bytes contains the start address of the 8 returned bytes.	5
11	17	1-8	<i>Read 64 Bit Command.</i> This command reads 8 bytes of data from the external hardware. The LSB of the returned data is address zero. This commands requires external hardware. See USB64BIO-Sch.pdf on our website.	8
11	18	1-8	<i>Write 2 bytes, Read 8 byte Command.</i> This command reads 8 bytes of data from the external hardware, similar to the above command. But the data in DataLSB and DataMSB is write to the write address latch 0 and 1 respectively. This command was added to increase through put. This commands requires external hardware. See USB64BIO-Sch.pdf on our website.	10
11	50	0	<i>Reads the RS232 Rx Buffer.</i> This byte returns 8 bytes, the first byte is the Rx Buffer Status and data count and the remaining bytes are the RS232 data bytes. The Rx buffer is 7 bytes deep and is in LSB first order. The Rx Status and data count byte are cleared when this command is issued. The lower nibble of the status byte contains the Rx buffer data length count, pin 7of 7 of the rx status byte is set on an Rx overflow and pin 6 of 7 is set on a Rx framing error. Note you can read both the Rx Status and Tx Status bytes with command 11-9 without clearing there content.	5

11	60	0	<p><i>Reads from the I2C Port.</i></p> <p>Reads 1 to 8 bytes of data from the I2C port. The device address/command is set in the data LSB byte and the number of requested bytes to read is set in the data MSB byte. If an error occurs bit 4/7 of byte 7 is set, else reset. See command 11-9.</p>	6
11	61	0	<p><i>Selective Reads from the I2C Port.</i></p> <p>This function sends a selective read command to the device, allowing the selective address to be sent before the read command is sent. This command is typically used in nonvolatile RAM type device such as the Xicor X24C04. The device address/command is set in the data LSB and the number of bytes requested is set in the data MSB byte. The selective address is setup with command 10-61. This command produces the following sequence; start, device address from 10-61 LSB byte is sent, selective address byte from 10-61 MSB byte is sent, start is sent again, the device address/command (LSB data from this command) is sent, then the data from the device is read and returned to the user. If an error occurs bit 4/7 of byte 7 is set, else reset. See command 11-9.</p>	6
11	90	0-8	<p><b>Read SPI Data</b></p> <p>Reads up to 8 bytes (64bits) of data from the SPI port. To read data from the SPI port first send the 10-90 Write SPI data command and then send this command. This command only returns the SPI data from the last 10-90 command issued. LSB and MSB bytes not used.</p>	15 802x70
11	91	0-8	<p><b>Write 1Byte Read 1-64 bits SPI</b></p> <p>Writes 1 byte of SPI data with 64 clocks and then returns 64bits (8Bytes) of data. This command simultaneously writes/reads to increase through put. The LSB byte should be set to the number of clocks required. The MSB byte should be sent to the byte to write. The write size limited to 1 byte.</p>	15 802x70

## 6.0 Typical Schematic

Note - External oscillator not required on 802x70 chips.

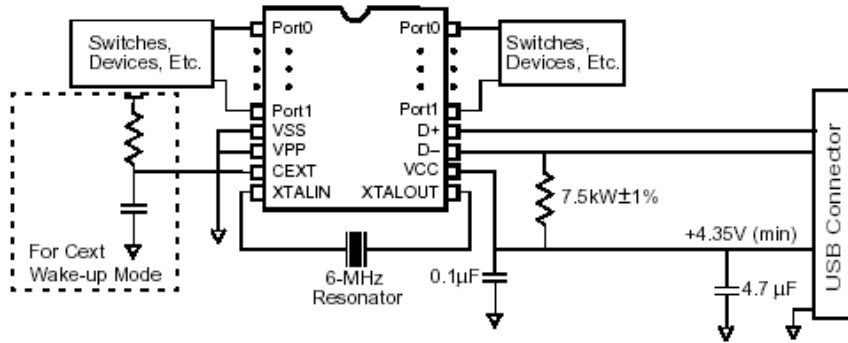

## 7.0 Specifications

### 7.1 Absolute Maximum Ratings

Storage Temperature	-65C to +150C
Operating Temperature	-0C to +70C
Vss relative to Vcc	-0.5V to +7.0V
DC Input Voltage	-0.5V to Vcc+0.5V
DC voltage on HiZ pins	-0.5V to Vcc+0.5V
Max Current Summed on Port1 pins	60ma
Max Current Summed on Port0 pins	10ma
Power Dissipation	300mW
Static Discharge Voltage	>2000V
Latch Up Current	200mA

### 7.2 Electrical Characteristics

Vcc Operating Current	25mA
Vcc Limits	4 to 5.25V
Port 0 Max Current Sink	1.5mA
Port 0 Min Current Sink	0.3mA
Port 1 Max Current Sink	24mA
Port 1 Min Current Sink	4.8mA
Pull Up Resistor	16Kohms
Input Hysteresis Voltages P0 & P1	Min6% Max12% Vcc
Packet Bandwidth	100 Packet/sec

## 8.0 Package Diagrams

20-Lead (300-Mil) Molded SOIC S5

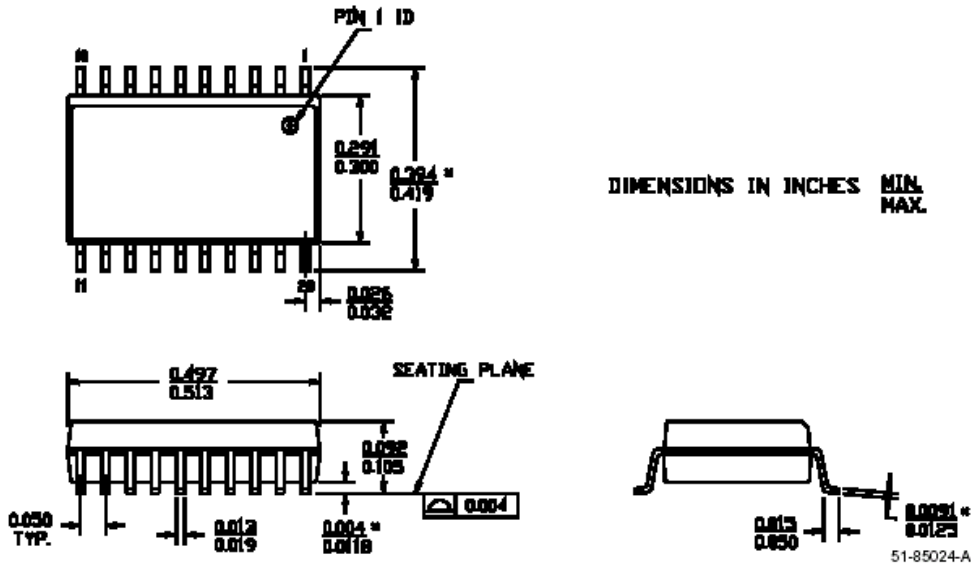

24-Lead (300-Mil) Molded SOIC S13

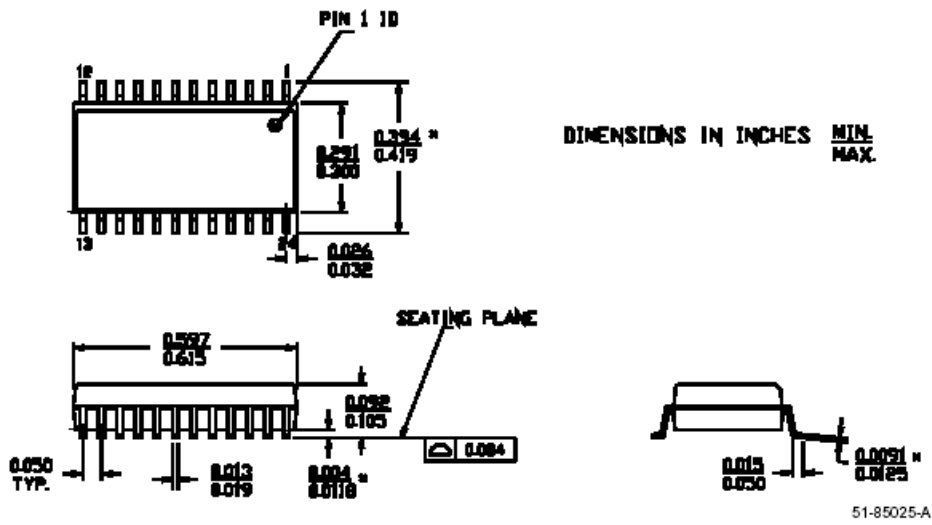

20 pin DIP 0.300" also available.

## 9.0 Ordering Information

Order Number	Number GPIO	Package Type
802600*	16	24 Pin (300Mil) SOIC
802300*	12	20 Pin (0.300") DIP
802200*	12	20 Pin (300Mil) SOIC
802270	10	18 Pin (300Mil) SOIC
802370	10	18 Pin (0.300") DIP
802670	16	24 Pin (300Mil) SOIC
802770	16	24 Pin (0.300") DIP

\* *Not recommended for new designs*

## 10.0 Firmware Release Notes

- Version 1 - Initial Release
- Version 2 - Added data strobe functions.
- Version 3 - Added event counter function.
- Version 4 - Fixed error with USB enumeration
- Version 5 - Added RS232 and 8 byte Strobe Functions.
- Version 6 - Added I<sup>2</sup>C communication functions.
- Version 7 - Added buzzer functions.
- Version 8 - Added 64 Bit Rd/Wr & Acknowledge pin.
- Version 9 - Fixed error with RS232 Rx function.
- Version 10 - Added 11-18 write 2 bytes & read 8 byte command.
- Version 11 - I2C fixed, regarding data contention during the ACK bit.
- Version 12 - 2005-05-25 Fixed I2C Stop condition introduced in v11. Changed I2C Start to SDA high, then SCLK high to improve Selective reads. Added command 11-62 - Selective read 16 bit, same as 11-61 but 16bit instead of 8bit address.
- Version 12 - 2005-06-16 Added PWM functions on pins P1.0, P1.1 and P1.2, 78.125Hz used for LED dimming, Default to 100(OFF) is USBIO and 80 in LAMP Firmware only.
- Version 13 - 2005-06-29 Added I2C clock stretching option to read and write commands. Maximum clock stretch per clock is 615us.
- Version 14 - 2005-09-19 Re-added command 11-18 that was dropped in version 11 by mistake.
- Version 15 - 2005-11-10 Added SPI support - P0.7=SPICLK P0.6=MOSI P0.7=MISO  
- Change port configuration to first write 0xFF to the data latch and then change the mode to open drain. Before the port mode was changed before the port data latch was set. This caused a momentary low on the output pins.
- Version 16 - 2005-11-16 Added string LUT max index test, code now returns a NAK if index is invalid. Before this fix the USB host could request a index to string passed the end of the table, this would cause the code to jump to a unknown location.
- Version 18 - 2006-04-02 Changed P0.3 to CMOS drive type of USBVIDEL (Beacon only).
- Version 19 - 2006-04-02 Change code to check data\_toggle on WRITE-OUTS. Before the code was checkin the DataVaild bit twice instead of the Data ;valid and datatoggle bits.  
- 2009- Added Toggle Pin Command.
- Version 20 - 2009-07-03 Changed SPI to just toggle the clock from where it started from. Allows users to use rising or falling clocks with SPI.
- Version 21 - 2009-10-08 Added Toggle Pin Command.

## 11.0 Trouble Shooting

If Windows does not see the USB device in the Windows Device Manager or it is listed as an 'Unknown device' then you have a hardware problem. Most common errors are; Reserved D+/D- (green/white) wires, 7.5K 1% resistor on incorrect pin, Missing +5Volts or Ground, and VPP pin not tied to ground. Make sure your cuicuit matches the USBIODEVSCH.pdf schematic available on the web.

## 12.0 Notes

### 12.1 Power Notes

When the device boots up the total current consumed by the device should be at a minimum to comply with the USB standard.

Cable length and cable size should be selected in order to maintain an operating voltage at the USB I/O chip of at least 4Volts.

This device can be used in a self-powered mode or with an external power supply if more than 450mA is required by user. When using external power supplies, connect the USB I/O chip Vcc to the USB supplied power and run the user added circuitry off the external power supply. Do not connect the USB Vcc and external power supplies together, only connect the grounds.

### 12.2 Interfacing

When interfacing the USB I/O chip to other circuitry, one must be careful not to over load the current on the pins and not to exceed the voltage on the pins. If the voltage or current is greater than and/or less than the levels on the USB I/O chip, you will have to add some sort of buffering or interfacing. For example most relays require more than 25mA to actuate the relay, and the USB I/O device can only sink 25mA. Therefore a current amplifier is required, such as a transistor. When working with excessive currents, voltages or with high EMI circuits it is recommended that you use relays and/or opto-couplers to isolate the circuits. See 'Interfacing to USB I/O Devices' on the website.